

CNC 200MM COIL WINDER

INSTRUCTIONS

IMPORTANT: PLEASE READ THESE INSTRUCTIONS CAREFULLY TO ENSURE THE SAFE AND EFFECTIVE USE OF THIS MACHINE.

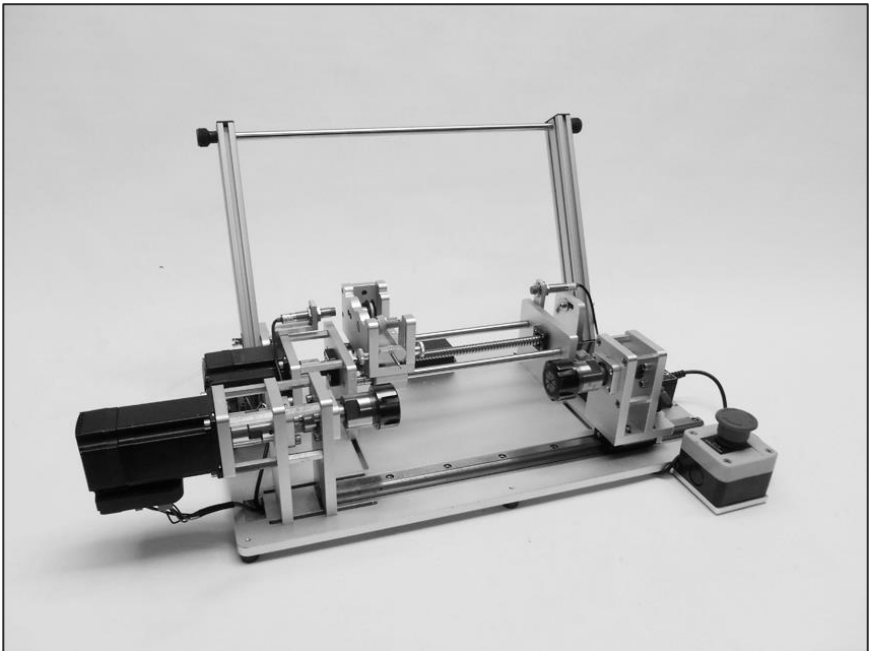



CONTENTS

Declaration Of Conformity	2
Specification	3
Warranty	3
Safety Warning.....	4
Maintenance	4
Getting To Know Your Coil Winder	5
Operation And Use.....	6-9
Installing Software	10 - 11

GENERAL INFORMATION

This manual has been compiled by CNC Design Ltd and is an integrated part of the product with which it is enclosed and should be kept with for future references.

This manual describes the purpose for which the product has been designed and contains all the necessary information to ensure its correct and safe use. We recommend that this manual is read before any operation or, before performing any kind of adjustment to the product and prior to any maintenance tasks. By following all the general safety instructions contained in this manual it will ensure both the product and operator safety, together with longer life of the product itself.

All photographs and drawings in this manual are supplied by CNC Design Ltd to help illustrate the operation of the product.

Whilst every effort has been made to ensure accuracy of information contained in this manual, the CNC Design Ltd policy of continuous improvement determines the right to make modifications without prior warning.

DECLARATION OF CONFORMITY



CERTIFICATE & DECLARATION OF CONFORMITY FOR CE MARKING

Company contact details:

CNC Design Limited
Unit 5S Larvale Estate, St Columb Major Industrial Estate, Cornwall, TR9 6SF, England
Tel: +44 1637 881520 info@ukcnc.info

CNC Design Limited declares that their:

Desktop CNC Coil Winder Model MK1x
Desktop CNC 200mm Coil Winder
Desktop Mini Coil Winder

comply with the Essential Requirements of the following EU Directives:

Machinery Directive 2006/42/EC
Electromagnetic Compatibility Directive 2004/108/EC
EU RoHS 2 Directive 2011/65/EU

and further conform with the following EU Harmonized Standards:

EN ISO 12100:2010
EN 61000-6-3:2007+A1:2011
EN 61000-6-1:2007

Dated: 17 February 2015

Position of signatory: Director

Name of Signatory: Sean Hegarty

Signed below:

on behalf of CNC Design Limited

SPECIFICATION

The CNC Design Ltd policy of continuous improvement determines the right to change specification without notice.

Dimensions of base plate (L x W)	525mm x 300mm
Weight	15Kg
Maximum feeder travel	Approx. 200mm
Maximum Servo motor add-on RPM	2200 RPM
Maximum Stepper motor RPM	1500 RPM
Maximum bobbin diameter	150mm
Wire range	0.02mm-0.8mm(1mm single layer)
Feeder max resolution	0.0025mm

WARRANTY

12 months Return to Base warranty is offered all assembled machines. This is on a Return to Base policy which means the customer will be liable to pay for the shipping of the faulty parts back to us and we will be liable for the cost of replacing and shipping back to the customer.

SAFETY WARNING

Keep hands clear of moving parts during operation.

Ensure the chucks are fully tightened and the tailstock is fully locked down before operating.

Make sure the power is switched off before connecting the power supply to the DC box.

MAINTENANCE

The machine has been designed to be low maintenance.

Your machine has been delivered dry as such to keep the machine as clean as we can when assembling.

Please make sure to apply grease to the Ball screw and all the rails before running the machine too hard or fast.

Any moving parts such as the feeder ball screw and the tailstock rail needs to be lightly greased periodically depending on use.

Check the tightness of all nuts and bolts.

GETTING TO KNOW YOUR COIL WINDER

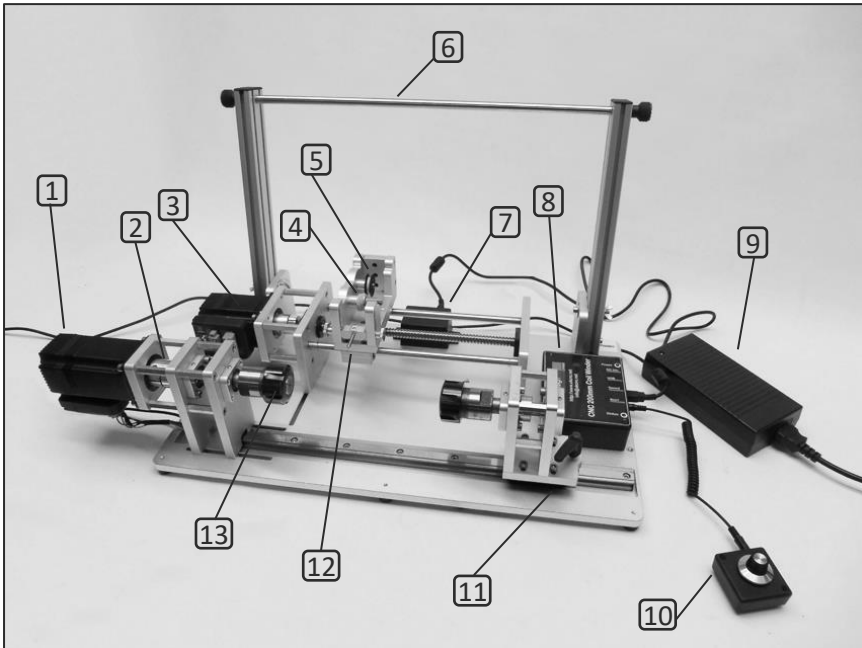

1	Closed Loop Servo/Stepper Motor	8	Controller Box
2	Coupler	9	Power Supply
3	Closed Loop Stepper Motor	10	Manual Wind Control
4	Felt Wire Tensioner	11	Tailstock
5	Porcelain Wire Guide Pulley	12	Ruby Tipped Nozzle
6	Adjustable Spool Bar	13	ER25 Chucks
7	DC Power Box		

OPERATION AND USE

Remove Machine from box, remove wrapping and bubble wrap.



Please check the items against the checklist in the box.



Bolt Bobbin motor onto the frame.

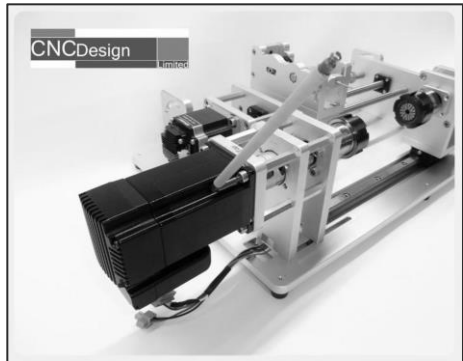

OPERATION AND USE

Plug in the connectors and tighten the 2 screws on the power block.



Adjust the 4 motor screws and 6 feeder screws to the position you require. Make sure both are nice and square.

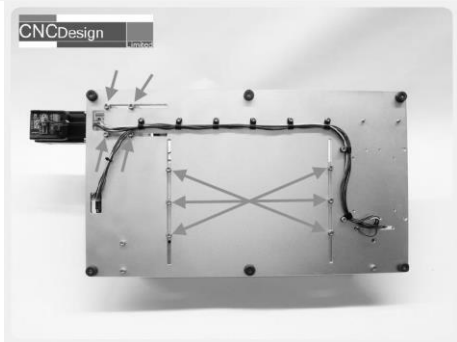

Insert nozzle and tighten off the 4mm grub screw.

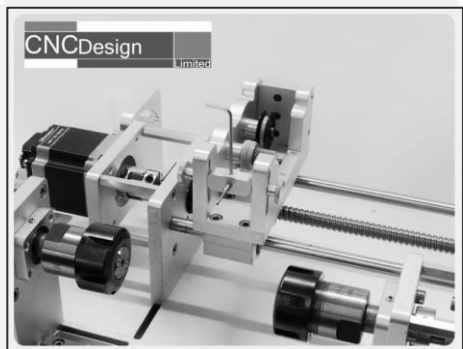

OPERATION AND USE

Prepare upright arms, bolts and top bar.

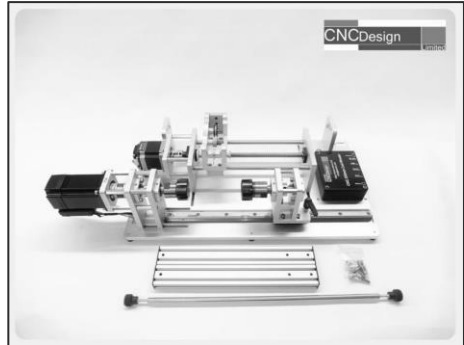

Attach the M5 X 25mm screws in the bottom of each arm. Attach the M5 x 40mm bolts with washers and wing nuts.

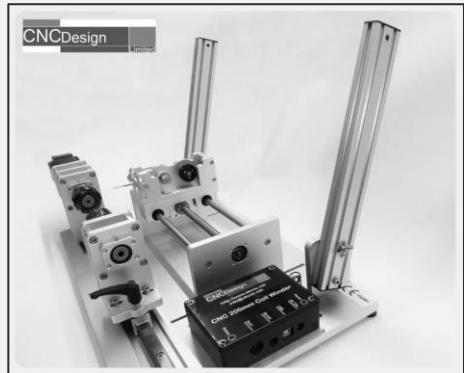

Attach top bar as shown and tighten off knurled knobs.

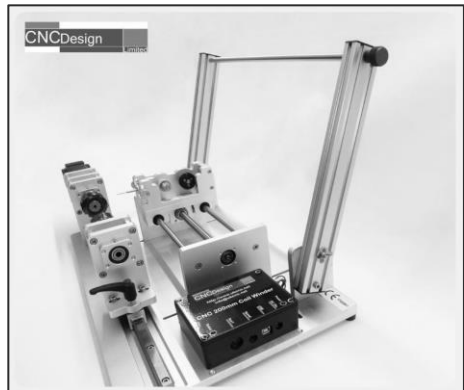

OPERATION AND USE

Make sure the DC power box is switched off before connecting.



Attach manual controller, power supply and USB lead. Then plug the USB into computer.

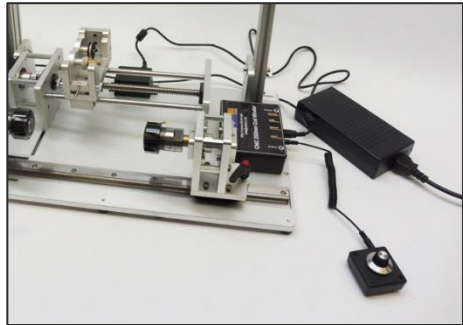

All complete and ready to run up the software and test.

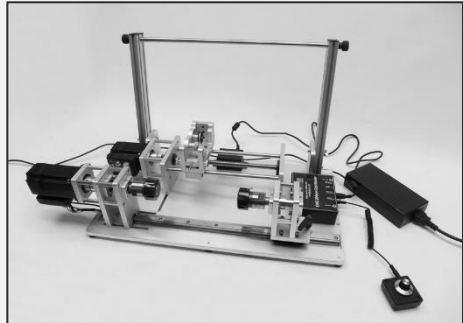

GENERAL INFORMATION

A Larger document with clearer instructions can be viewed via our website
<http://www.ukcnc.net>

INSTALLING SOFTWARE

Insert the enclosed USB stick into your computer, browse to the device and run setup.exe.

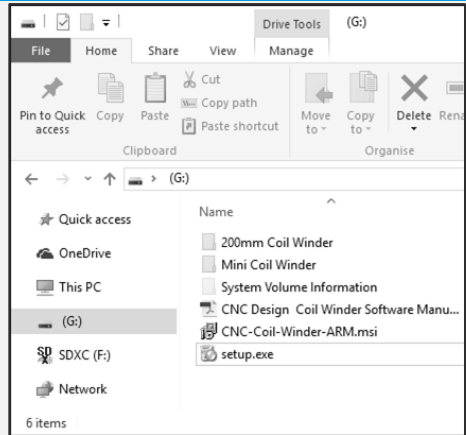

Proceed through the wizard.

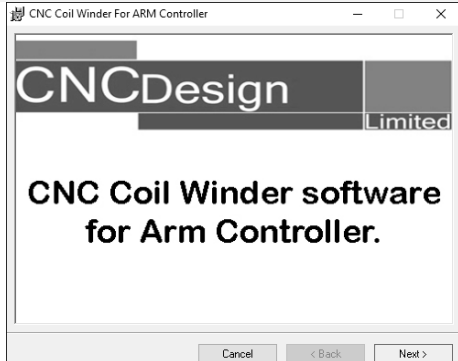

Here you can select the installation folder and choose to install this for multiple users or a single user.

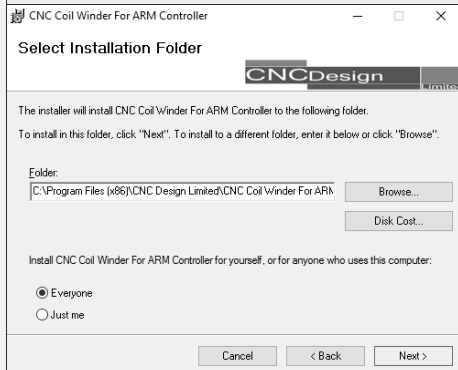



CONTACT DETAILS

CNC Design limited,
Unit 5S Lanvale Estate,
St. Columb Major,
Industrial Estate,
Cornwall,
TR9 6SF,
England

Telephone: +44(0) 1637 881520

Web: <http://www.ukcnc.net>

Email: info@ukcnc.net

©PUBLISHED BY CNC DESIGN LTD.

No part of this publication may be reproduced, stored in a retrieval system or transmitted in any form or by any means, electronic, mechanical photocopying, recording or otherwise without prior permission in writing from CNC Design Ltd.

NOTES

NOTES