



CNC D-500 Mechanical Checklist-V1

<http://www.ukcnc.net>

Contents

Plate Checklist.....	2
Linear Checklist.....	20
Bolt Checklist.....	22

DC-Plate 1	Quantity	1	Packing Check	<input type="checkbox"/>	Customer Check	<input type="checkbox"/>
-------------------	----------	---	---------------	--------------------------	----------------	--------------------------

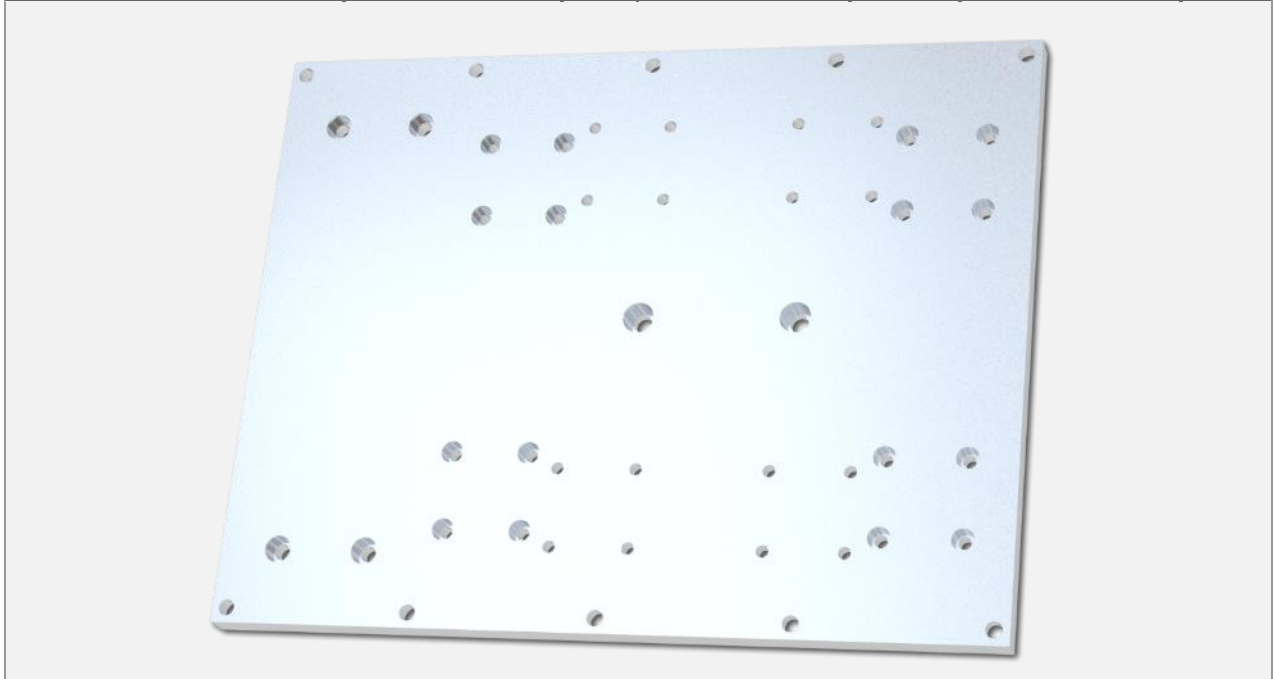

DC-Plate 2	Quantity	1	Packing Check	<input type="checkbox"/>	Customer Check	<input type="checkbox"/>
-------------------	----------	---	---------------	--------------------------	----------------	--------------------------

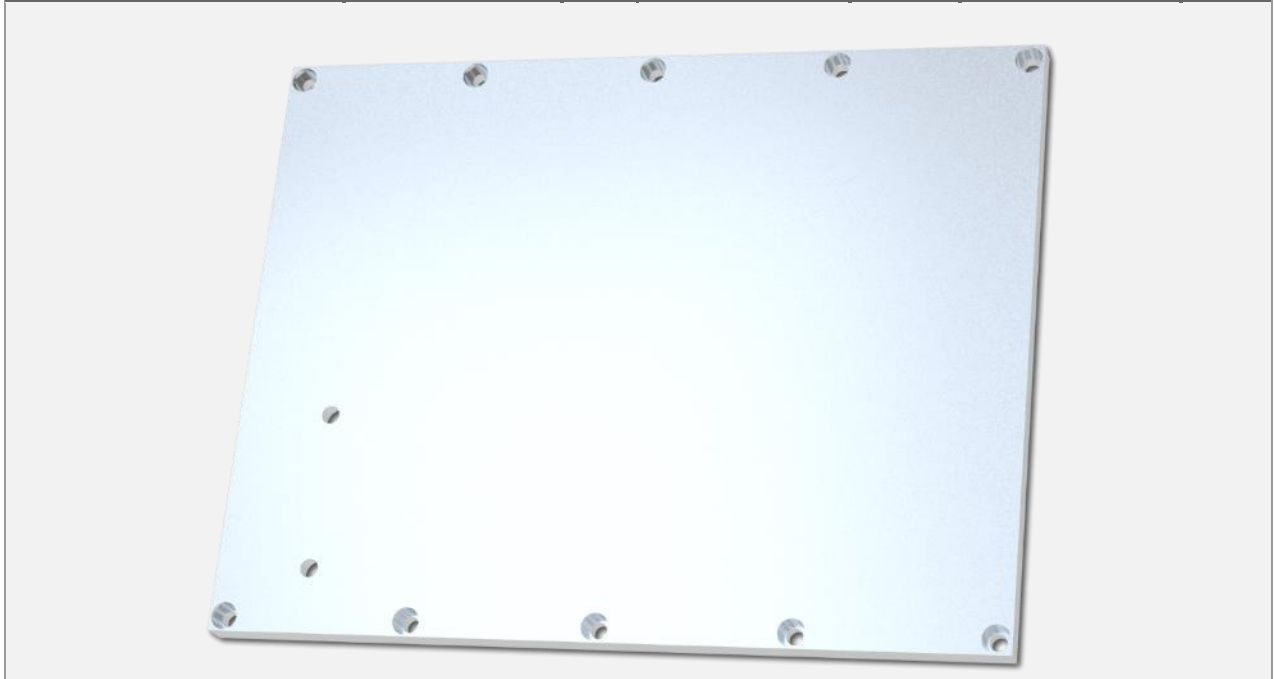

DC-Plate 3	Quantity	2	Packing Check	<input type="checkbox"/>	Customer Check	<input type="checkbox"/>
						

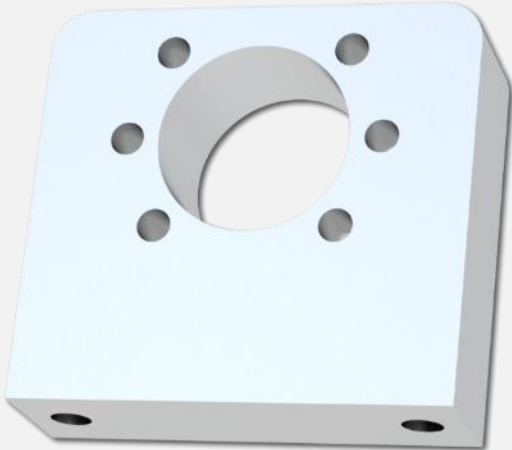
DC-Plate 4	Quantity	1	Packing Check	<input type="checkbox"/>	Customer Check	<input type="checkbox"/>
						

DC-Plate 5	Quantity	1	Packing Check	<input type="checkbox"/>	Customer Check	<input type="checkbox"/>
-------------------	----------	---	---------------	--------------------------	----------------	--------------------------

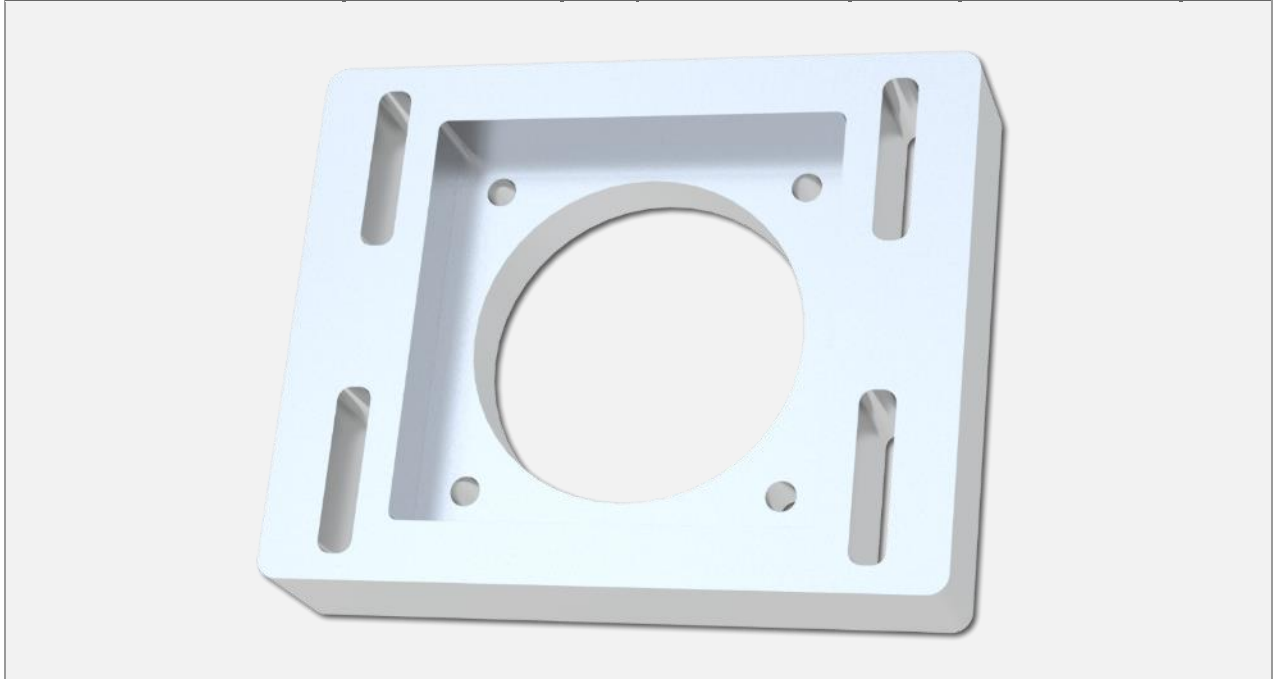

DC-Plate 6	Quantity	1	Packing Check	<input type="checkbox"/>	Customer Check	<input type="checkbox"/>
-------------------	----------	---	---------------	--------------------------	----------------	--------------------------

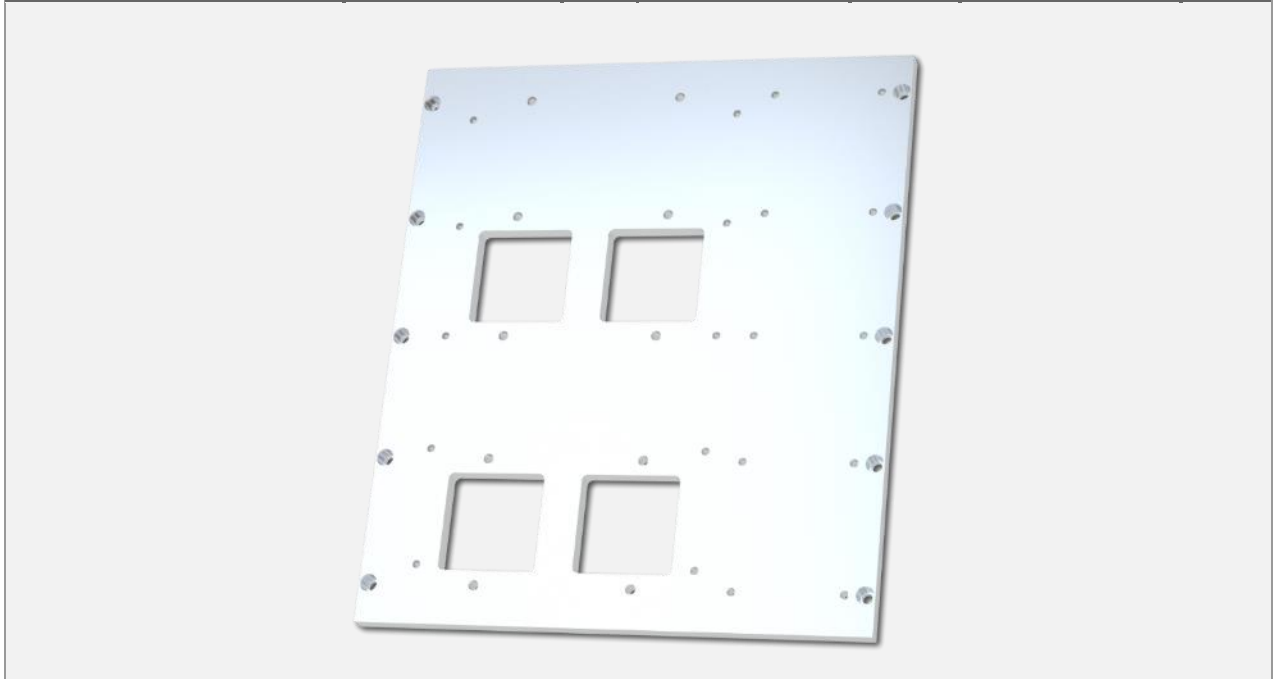

DC-Plate 7	Quantity	2	Packing Check	<input type="checkbox"/>	Customer Check	<input type="checkbox"/>
						

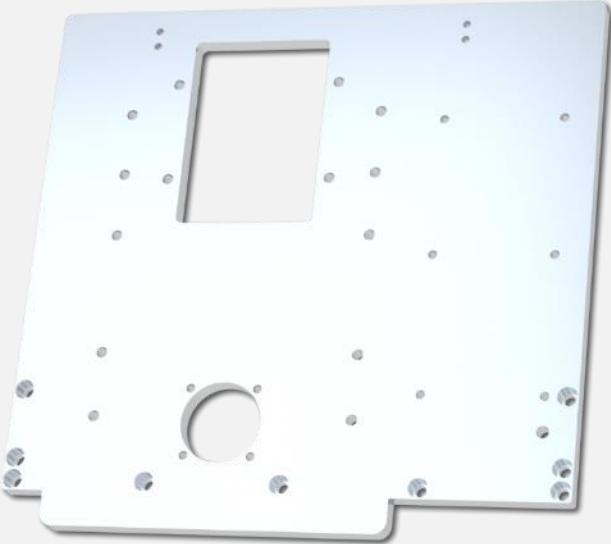
DC-Plate 8	Quantity	1	Packing Check	<input type="checkbox"/>	Customer Check	<input type="checkbox"/>
						

DC-Plate 9	Quantity	1	Packing Check	<input type="checkbox"/>	Customer Check	<input type="checkbox"/>
						

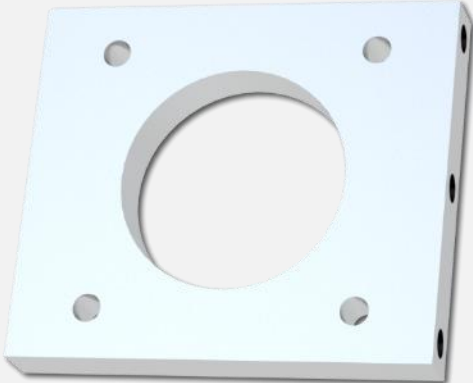
DC-Plate 10	Quantity	1	Packing Check	<input type="checkbox"/>	Customer Check	<input type="checkbox"/>
						

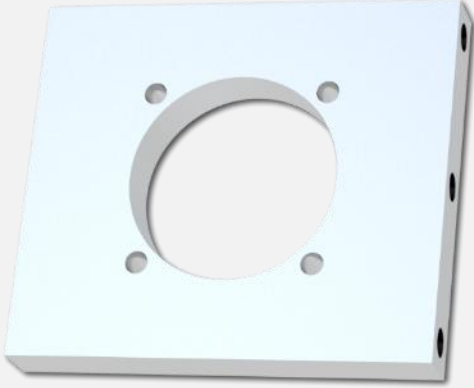
DC-Plate 11	Quantity	1	Packing Check	<input type="checkbox"/>	Customer Check	<input type="checkbox"/>
						

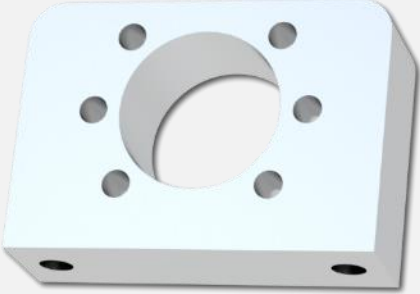
DC-Plate 12	Quantity	1	Packing Check	<input type="checkbox"/>	Customer Check	<input type="checkbox"/>
						

DC-Plate 13

Quantity

2

Packing
Check

Customer
Check

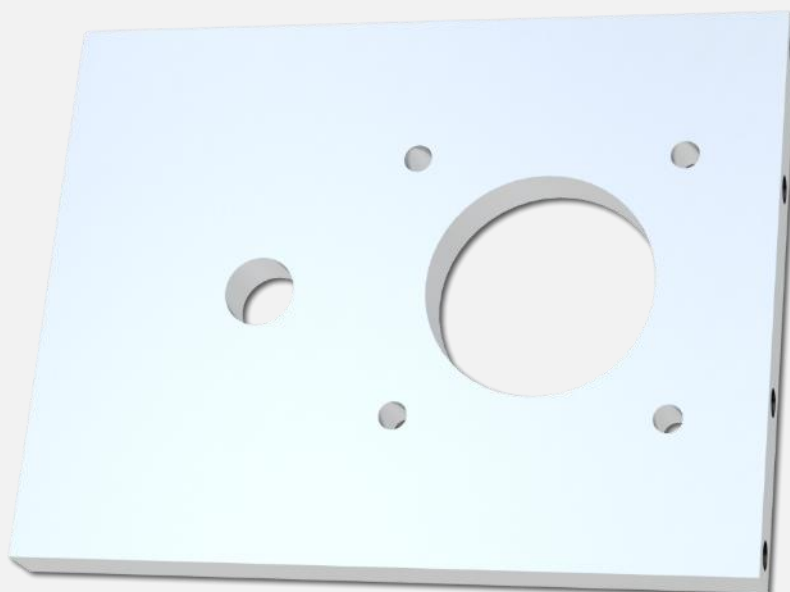

DC-Plate 14

Quantity

2

Packing
Check

Customer
Check

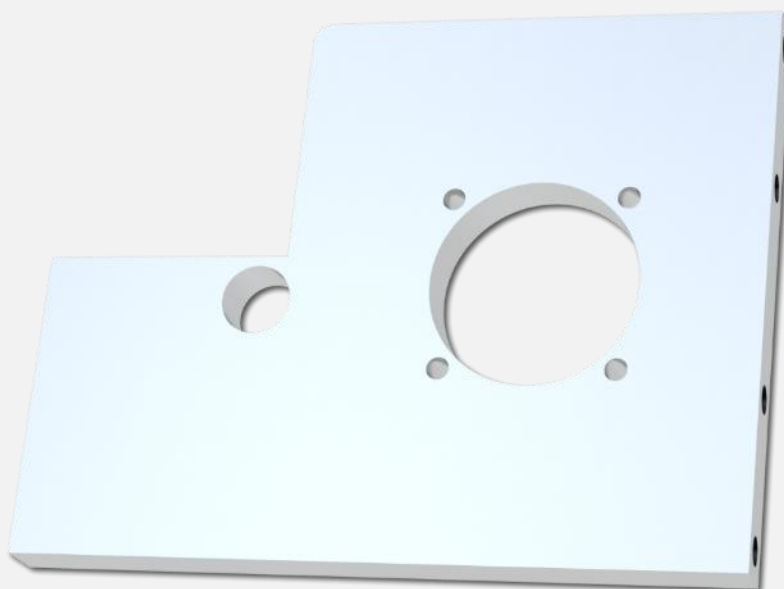

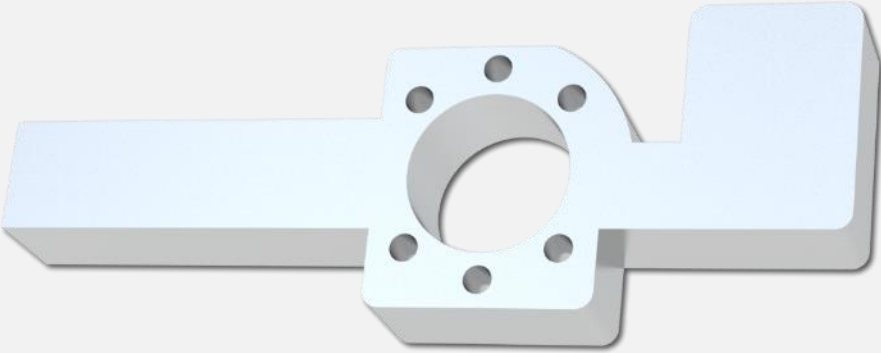

DC-Plate 15	Quantity	12	Packing Check	<input type="checkbox"/>	Customer Check	<input type="checkbox"/>
						

DC-Plate 16	Quantity	2	Packing Check	<input type="checkbox"/>	Customer Check	<input type="checkbox"/>
						

DC-Plate 17	Quantity	2	Packing Check	<input type="checkbox"/>	Customer Check	<input type="checkbox"/>
						

DC-Plate 18	Quantity	1	Packing Check	<input type="checkbox"/>	Customer Check	<input type="checkbox"/>
						

DC-Plate 19	Quantity	2	Packing Check	<input type="checkbox"/>	Customer Check	<input type="checkbox"/>
						

DC-Plate 20	Quantity	2	Packing Check	<input type="checkbox"/>	Customer Check	<input type="checkbox"/>
						

DC-Plate 21	Quantity	2	Packing Check	<input type="checkbox"/>	Customer Check	<input type="checkbox"/>
						

DC-Plate 24	Quantity	1	Packing Check	<input type="checkbox"/>	Customer Check	<input type="checkbox"/>
						

DC-Plate 25	Quantity	1	Packing Check	<input type="checkbox"/>	Customer Check	<input type="checkbox"/>
						

DC-Plate 26	Quantity	2	Packing Check	<input type="checkbox"/>	Customer Check	<input type="checkbox"/>
						

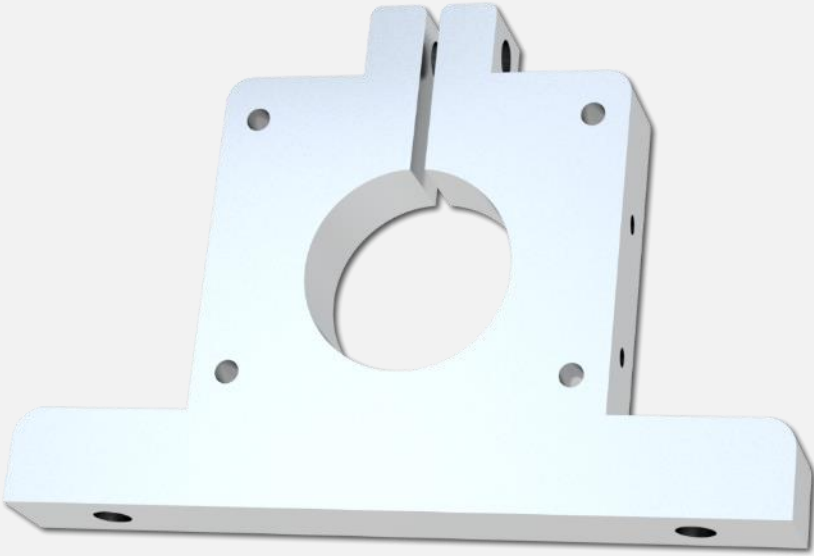
DC-Plate 27	Quantity	1	Packing Check	<input type="checkbox"/>	Customer Check	<input type="checkbox"/>
						

DC-Plate 28	Quantity	1	Packing Check	<input type="checkbox"/>	Customer Check	<input type="checkbox"/>
						

DC-Plate 29	Quantity	1	Packing Check	<input type="checkbox"/>	Customer Check	<input type="checkbox"/>
						

DC-Plate 30	Quantity	1	Packing Check	<input type="checkbox"/>	Customer Check	<input type="checkbox"/>
						

DC-Plate 31	Quantity	1	Packing Check	<input type="checkbox"/>	Customer Check	<input type="checkbox"/>
						

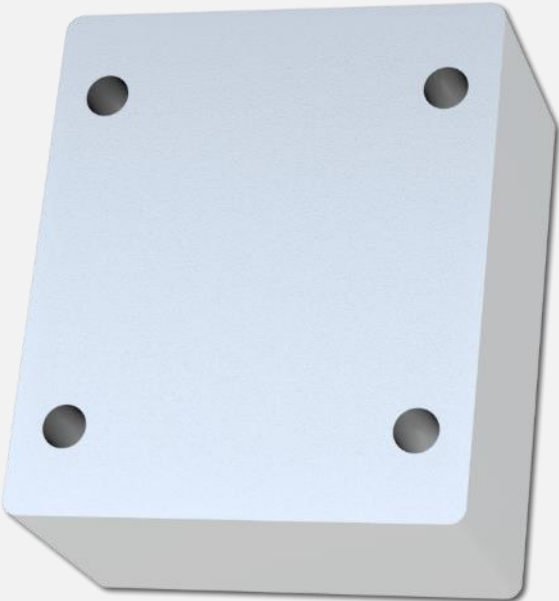
DC-Plate 32	Quantity	4	Packing Check	<input type="checkbox"/>	Customer Check	<input type="checkbox"/>
						

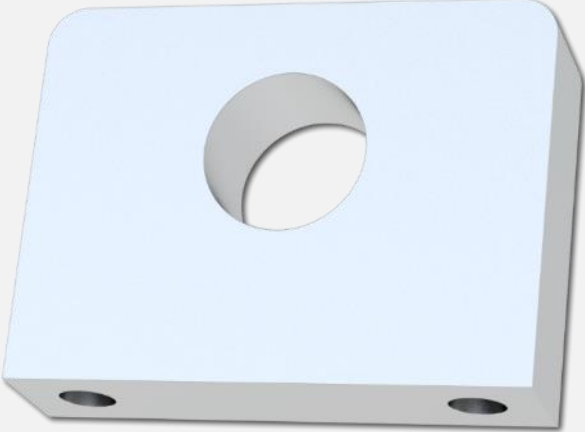
DC-Plate 33	Quantity	2	Packing Check	<input type="checkbox"/>	Customer Check	<input type="checkbox"/>
						





DC-Plate 34	Quantity	1	Packing Check	<input type="checkbox"/>	Customer Check	<input type="checkbox"/>
						



DC-Plate 44	Quantity	1	Packing Check	<input type="checkbox"/>	Customer Check	<input type="checkbox"/>
						

Alignment Plate	Quantity	2	Packing Check	<input type="checkbox"/>	Customer Check	<input type="checkbox"/>
						

Linear Checklist

<http://www.ukcnc.net>

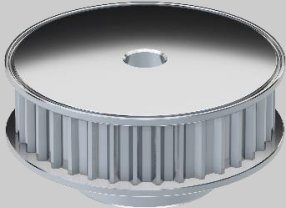
Name	Dimensions	Quantity	Packing Check	Customer Check
16mm x 655mm Long C7 Ballscrew		3	<input type="checkbox"/>	<input type="checkbox"/>
16mm x 365mm Long C7 Ballscrew		1	<input type="checkbox"/>	<input type="checkbox"/>
10mm – 8mm Coupler		3	<input type="checkbox"/>	<input type="checkbox"/>
HTD5 15mm x 420mm Belt		1	<input type="checkbox"/>	<input type="checkbox"/>

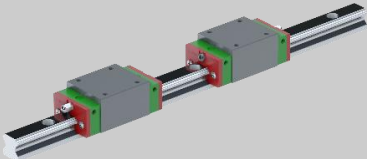
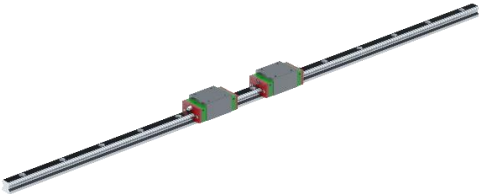
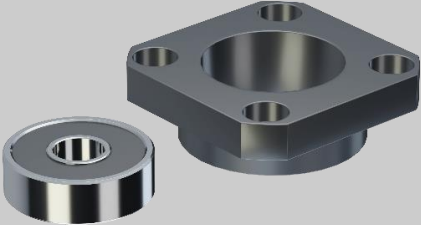
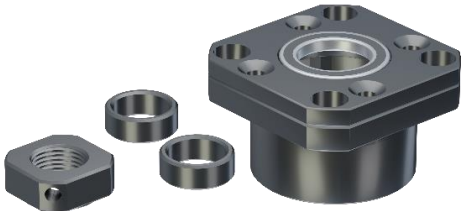
Name	Dimensions	Quantity	Packing Check	Customer Check
36 Tooth HDT5 Pulley		1	<input type="checkbox"/>	<input type="checkbox"/>
18 Tooth HDT5 Pulley		1	<input type="checkbox"/>	<input type="checkbox"/>
298mm long rail + 2 Carriages		2	<input type="checkbox"/>	<input type="checkbox"/>
768mm long rail + 2 Carriages		6	<input type="checkbox"/>	<input type="checkbox"/>
FF12 Ballscrew Support Unit		4	<input type="checkbox"/>	<input type="checkbox"/>
FK12 Ballscrew Support Unit		4	<input type="checkbox"/>	<input type="checkbox"/>

Bolt Checklist

<http://www.ukcnc.net>

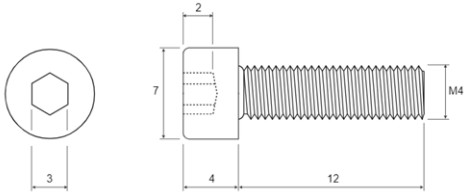
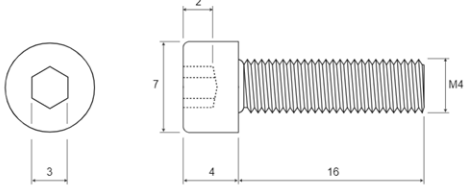
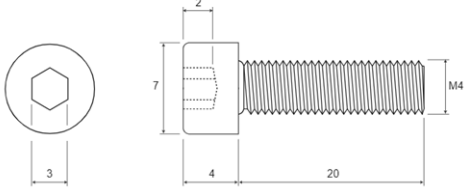
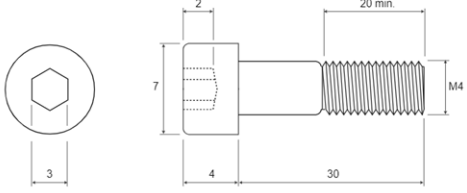
Name	Dimensions	Quantity	Packing Check	Customer Check
M4 x 12mm		32	<input type="checkbox"/>	<input type="checkbox"/>
M4 x 16mm		104	<input type="checkbox"/>	<input type="checkbox"/>
M4 x 20mm		32	<input type="checkbox"/>	<input type="checkbox"/>
M4 x 30mm		16	<input type="checkbox"/>	<input type="checkbox"/>

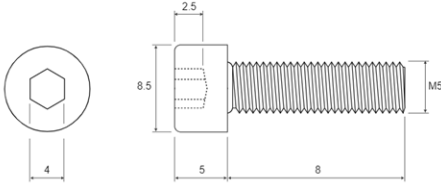
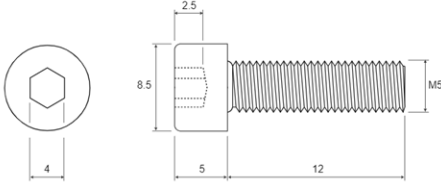
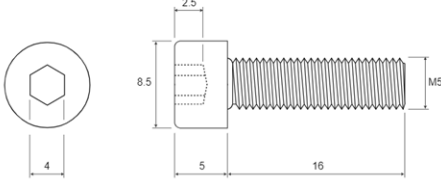
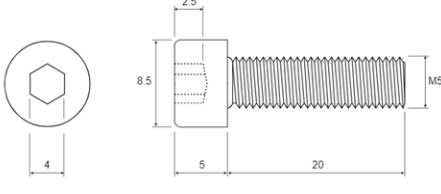
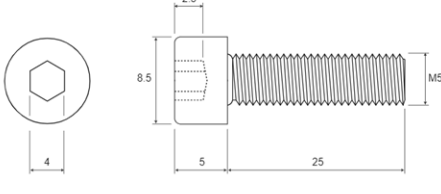
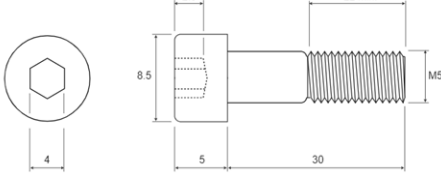
Name	Dimensions	Quantity	Packing Check	Customer Check
M5 x 8mm		5	<input type="checkbox"/>	<input type="checkbox"/>
M5 x 12mm		20	<input type="checkbox"/>	<input type="checkbox"/>
M5 x 16mm		56	<input type="checkbox"/>	<input type="checkbox"/>
M5 x 20mm		10	<input type="checkbox"/>	<input type="checkbox"/>
M5 x 25mm		144	<input type="checkbox"/>	<input type="checkbox"/>
M5 x 30mm		4	<input type="checkbox"/>	<input type="checkbox"/>

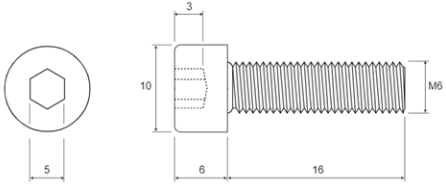
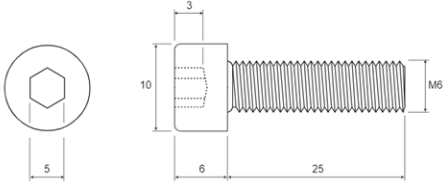
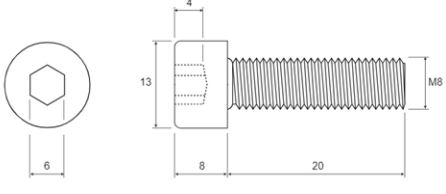
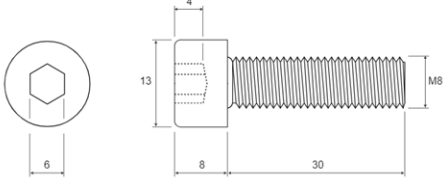
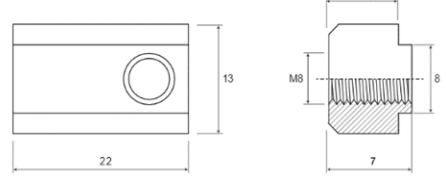
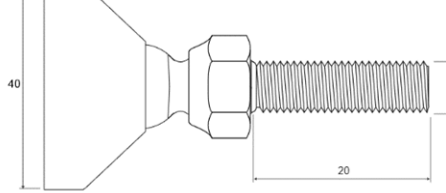
Name	Dimensions	Quantity	Packing Check	Customer Check
M6 x 16mm		4	<input type="checkbox"/>	<input type="checkbox"/>
M6 x 25mm		58	<input type="checkbox"/>	<input type="checkbox"/>
M8 x 20mm		2	<input type="checkbox"/>	<input type="checkbox"/>
M8 x 30mm		2	<input type="checkbox"/>	<input type="checkbox"/>
M8 T-Nut		4	<input type="checkbox"/>	<input type="checkbox"/>
M8 x 20mm x 40mm Feet		6	<input type="checkbox"/>	<input type="checkbox"/>

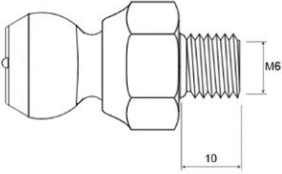
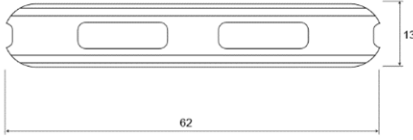
Name	Dimensions	Quantity	Packing Check	Customer Check
M6 Grease Nipple		4	<input type="checkbox"/>	<input type="checkbox"/>
Rail Insert		2	<input type="checkbox"/>	<input type="checkbox"/>