

MTC Series Magnetic Tensioner Product Manual

□MTCSS □MTCS □MTCM □MTCL □MTCLL

1 Product Introduction

MTC series are the vertical standard type of magnetic tension device, its principle is to generate damping by the magnetic field convert to torque change, no mechanical friction, can produce long-term stable tension, effectively ensure the precision accuracy. MTC series are standard type of magnetic tensioner, specification is shown as form on the right, you can choose the applicable model according to wire diameter scope. The function of the main component are as follow: wool felt can catch impurities of enamelled wire; tension pulley is core part of creating tension; tension adjust turntable can adjust tension value, the larger the scale interval, the greater the tension values; back tension adjust knob can adjust angle of tension arm.

Specification

Model	Reference wire	Tension scope
	diameter scope	
MTCSS	0.03-0.07	4.0-40
MTCS	0.04-0.14	10-120
MTCM	0.08-0.25	50-400
MTCL	0.12-0.35	80-600
MTCLL	0.14-0.40	100-800

2 Exterior Schematic Diagram

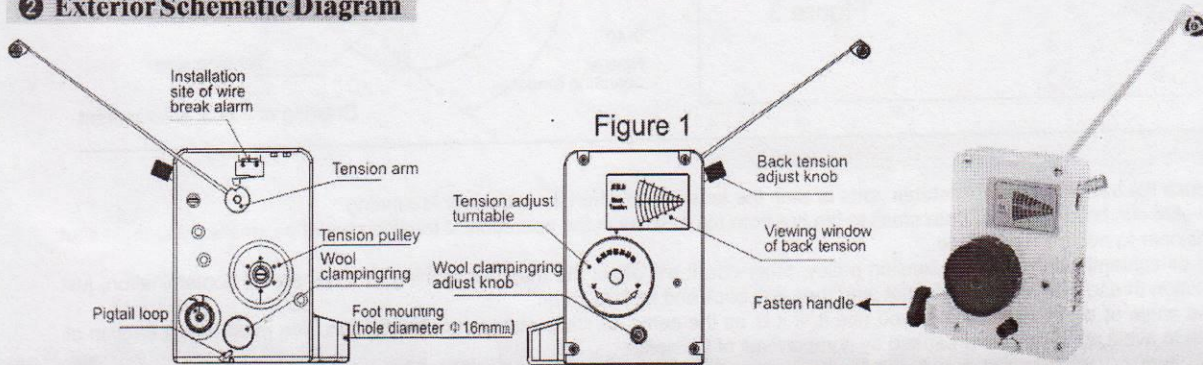

Product appearance depends on goods, the picture only supplies the reference!

3 Environmental conditions

1. Temperature range: -5°C-40°C Humidity range: 30%-80%.
2. Cleaning requirements of enamelled wire: Keep the enamelled wire without any oil, dust and impurity outside.

4 Operation

1. Installation

- Step1** Install tension arm and fasten lateral locking screw in accordance with the details shown in Figure 2. The screw should be aligned with the axial plane.
- Step2** Insert the foot mounting into fixed link and tighten it by fasten handle.

2. Commissioning

- Step1** Enamelled wire through the associated components of tensioner along the route as shown in figure 3 below. Note: The enamelled wire should be wrapped in wool felt of wool clamping ring in order to catch impurities. You can adjust degree of tightness of wool felt by wool clamping ring adjust knob. Wool felt should be appropriately relaxed to create tiny resistance when tension is small, on the contrary, it should be clamped when tension is large.

Figure 2

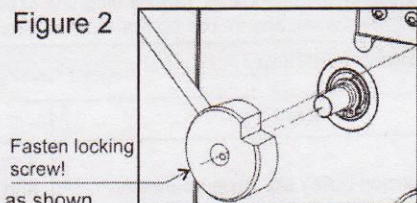

✂ Please retain the warranty cards by cutting along the dotted line.

Welcome to buy the series of products of our company. Please checking and accepting the product after opening the package.

NO.	ITEMS	QUANTITY	REMARKS
1	Magnetic Tensioner	1	Standard configuration
2	Servo Rod	1	Standard configuration
3	Fasten Handle	1	Standard configuration
4	Product Manual	1	Standard configuration
5	Wire break alarm	1	Optional
6	Warning holding wire	1	Optional

Note: Check all parts. If you find any defective or missing parts contact your local dealer when you opening the package.

MTC Magnetic Tensioner WARRANTY CARD

Username		Telephone	
Address			
Zip code		Purchase date	
Purchase address			
Retail price		Sales NO.	
Product type		Product's P/N	
Dealer signature		User signature	

(STAMPED)

Step2 Make sure the scale interval of tension adjust turntable and viewing window of back tension are transferred 0, and then began trial operation.

Step3 After tensioner operating, the position of tension arm will move down with the increase of tension value. Tensioner is at normal working status when tension arm within the realm of the 40 degrees below horizontal line(see figure 4). Tensioner will be above the horizontal line if tension is too small, you'd better raise tension to avoid abnormally wearing of tensioner.

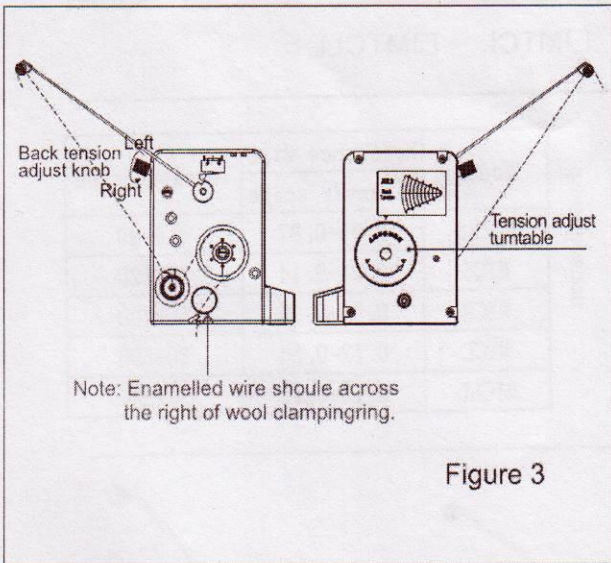

There are two methods for reference: (1) Turn the tension adjust turntable to the right to make tension arm fall down; (2) Turn the back tension adjust knob to the right. In contrast, if the tension arm is below normal work angle you should reduce tension — turn the back tension adjust knob to the left and try to keep the tension arm horizontal. You can adjust appropriate tension value according to this method. The relationship between wire diameter and tension value is recorded in a table which can be downloaded in our company's website. Normally, back tension value is proportional to tension value but less than it.

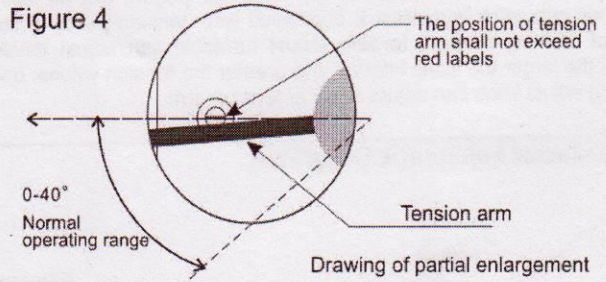

5 Note

- Do not touch the transmission or rotatable parts or stop the tension rod when the tensioner is running.
- Tension value can be only turned from small to big but from big to small in the operation! If tension should be smaller, you must shut down tensioner to avoid breaking line.
- Keep the oil contamination from the tension pulley, otherwise it will affect the machine running. If there are oil contamination, just use the cotton thread with absolute alcohol, and then pull back and forth to clean.
- Check the angle of tension arm before you use it, if it is as the same as static state when installation, you must adjust tension all over again to avoid abnormal wear caused by components of tensioner.
- It is prohibited to use does not match the machine operation; use is strictly prohibited over parameter limit; prohibited without consultation and disassemble parts.
- If the surface of enamelled wire with waxiness, you'd better clean wire rolling frequently and replace wool clamping ring regularly. Otherwise, it will cause frequent tension change or wire-through wheel skidding, and shorten operating life of O Ring in tension pulley.

6 Maintenance

- According to the use condition, regular cleaning of tension control, wool felt, Zhang Lilun, porcelain eyes, passing line wheel; replacement of wool; ensure the normal work of tension device.

7 Troubleshooting

FAULTS		TREATMENT
1	Tension pulley slip while operating	1,Clampe wool felt appropriately; 2,Use the cotton thread with absolute alcohol, and then pull back and forth to clean tension pulley; 3,Wrap around tension pulley by enamelled wire more than 1 in order to increase drags.
2	Tension pulsating exists	First turn right the tension adjust turntable to largest scale, and then turn left it from high to low slowly, turn around tension pulley continuously at the same time until pulsation disappear.

This instruction was revised in March, 2015, You will not be noted if any content changed.

Warranty Description:

- Our company promises: Since the products sold on the date of one year free warranty but the situation are not included in the repair guarantees as follow.
 - Outward appearance natural attrition.
 - The quality problems caused by irresistible natural disasters.
 - The damage from abnormal use or wrong operation.
 - The damage from the use of ultra-range caused by using wrong type.
 - The damage from improper storage by user.
 - The damage from repairing by self-disassembly without allowed by our company.
- Wool clamping ring, oriented porcelain parts, Wire-through Wheel, Tension rod are easily damaged so needed extra charge if replaced within warranty period.
- When the product appears a quality problem please send it and the warranty card back to our company and you are responsible for the postage.

Maintenance Records

	Date	Description of fault	Parts replaced	Serviceman	User signature
1					
2					
3					
4					
5					